

THIRD ANGLE PROJECTION

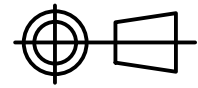

QUANTITY

WEIGHT N/A

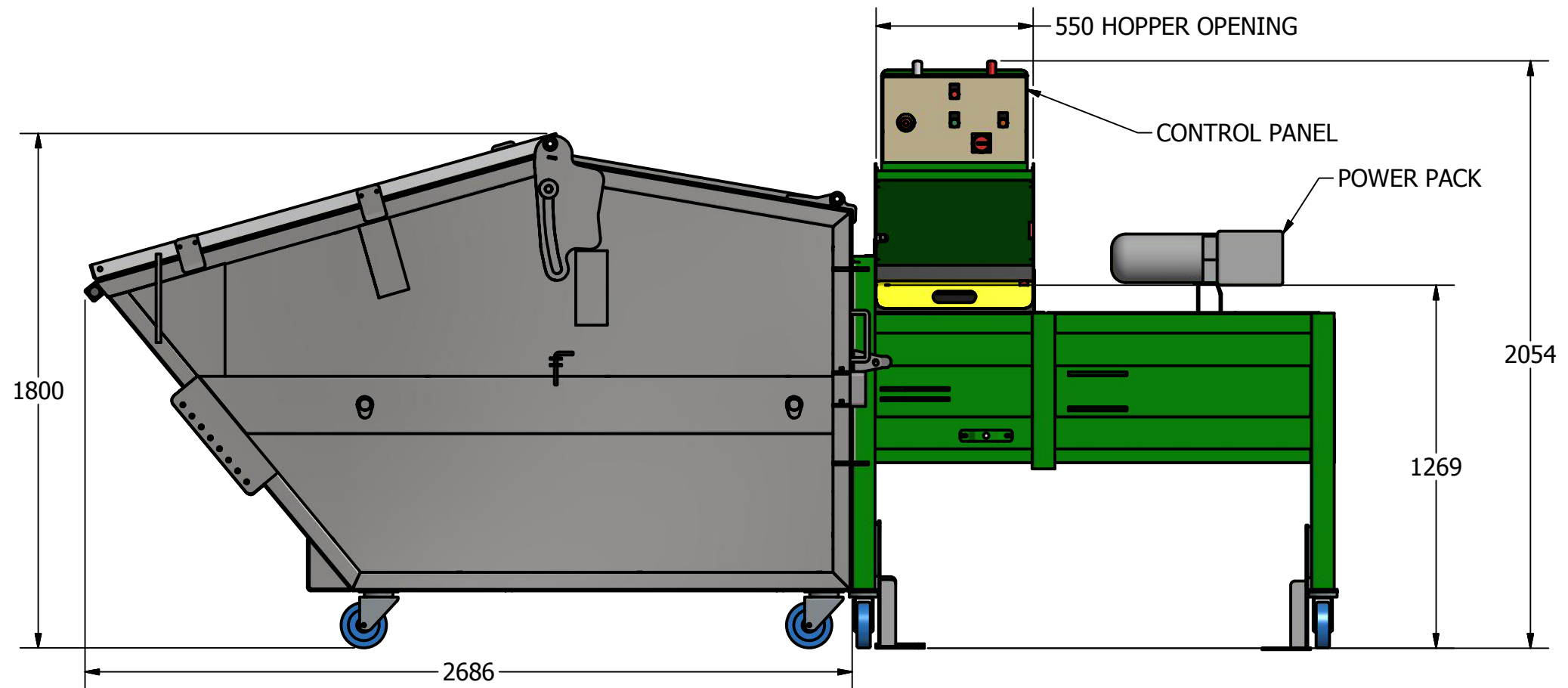

ELEVATION

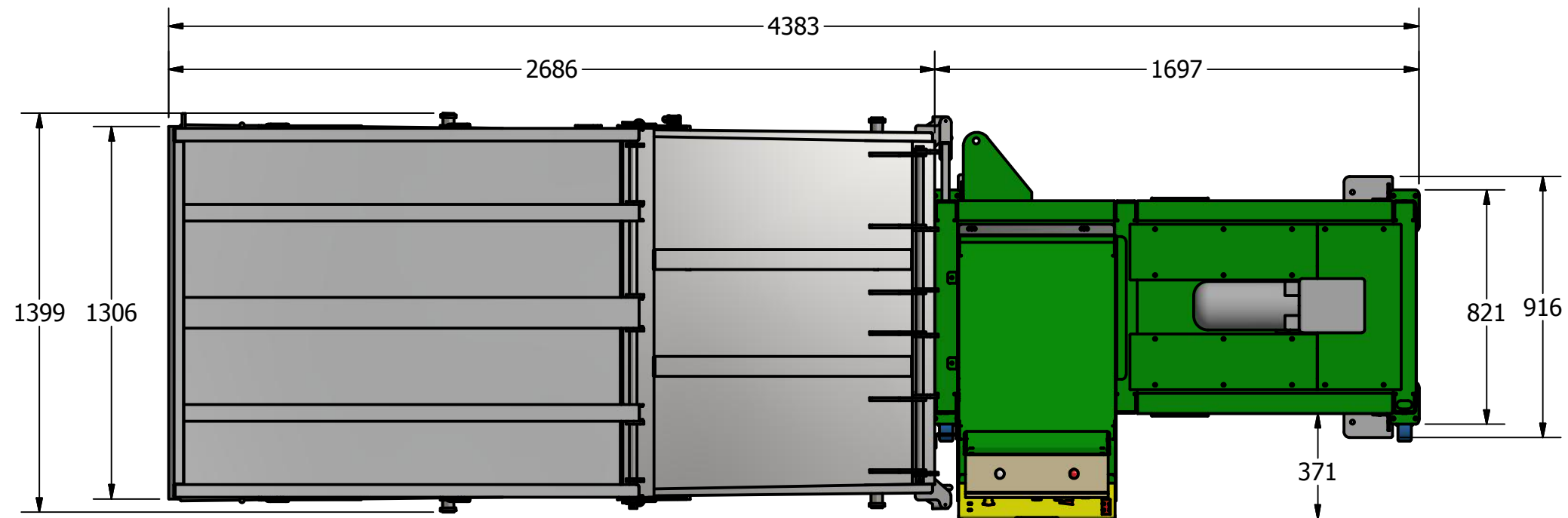

PLAN VIEW

REVISION NO	DESCRIPTION	REVISED BY	REVISED DATE		DRAWN BY	DRAWN DATE	MATERIAL:	TITLE:
				<small>ALL DIMENSIONS ARE IN MM AND ARE NOT SCALED. A BEND RADIUS OF THE MATERIAL THICKNESS TIMES 1 APPLIES TO ALL SHEET METAL COMPONENTS. WELD SYMBOLS TO ISO STANDARD I.S. EN 22553:1994. GENERAL TOLERANCE LINEAR +/- 1MM, ANGULAR +/- 1 DEG</small>	David.Dovle	14/05/2018		
							FINISH:	
				<small>THIS DOCUMENT IS THE PROPERTY OF LSM ENGINEERING LTD. IT MAY NOT BE COPIED COMMUNICATED OR USED FOR ANY OTHER PURPOSE OTHER THAN WHAT IT IS INTENDED FOR WITHOUT PERMISSION BY LSM ENGINEERING LTD</small>				DRAWING NO: _____ REV NO: _____ SHEET 1 OF 1 SHEETS